

TECHNICAL INSTRUCTIONS
FOR
SPECIAL SERVICE CAMPAIGN 9LG (SAFETY RECALL)
ACCELERATOR PEDAL MODIFICATION
2007 – 2010 MODEL YEAR ES

I. OPERATION FLOW CHART

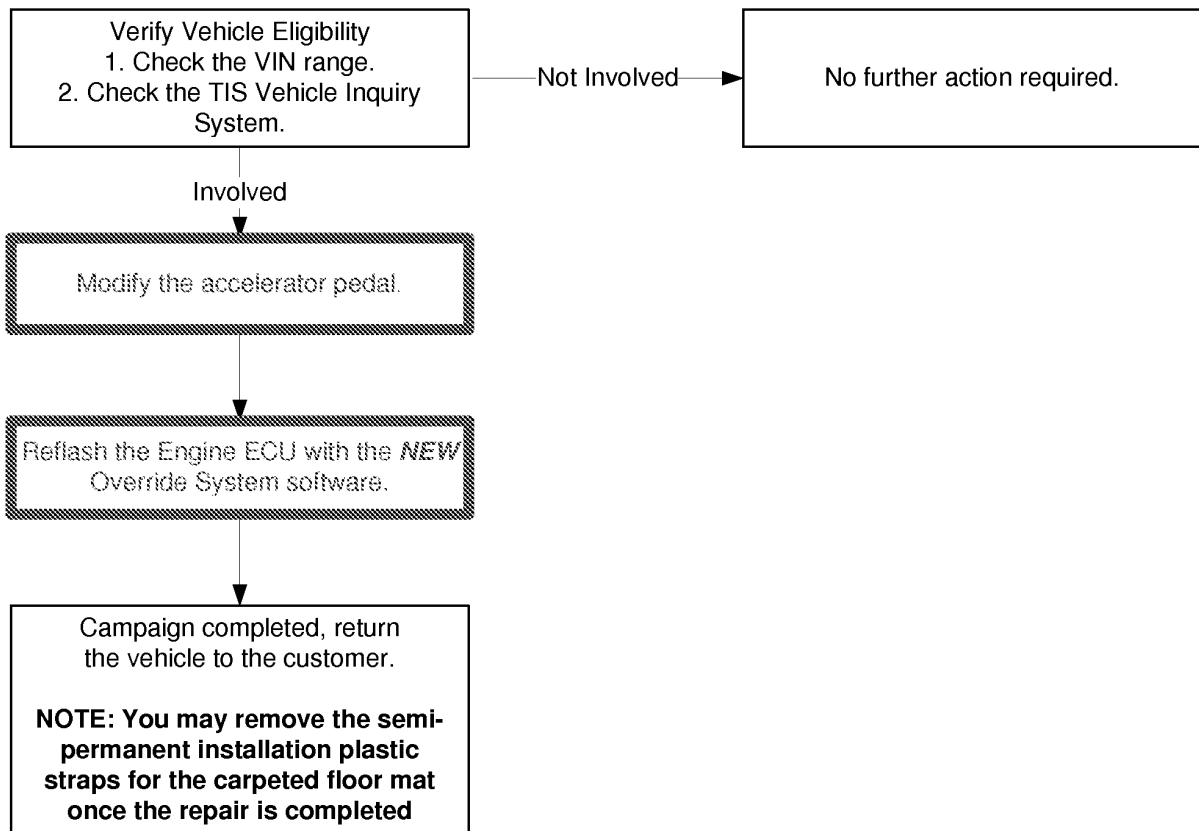

II. IDENTIFICATION OF AFFECTED VEHICLES

A. AFFECTED VIN RANGE

Model	WMI	Year	VIN Range		
			VDS	Range	
ES 350	JTH	2007	BJ46G	2	-2
		2008	BJ46G	2	-2
		2009	BJ46G	2	-2
		2010	BK1EG	2	- TBD

NOTE:

- Check the TIS Vehicle Inquiry System to confirm the VIN is involved in this SSC, and that the campaign has not already been completed prior to dealer shipment or by another dealer.
- TMS warranty will not reimburse dealers for repairs conducted on vehicles that are not affected or were completed by another dealer.

III. PREPARATION

A. PARTS

Part Number	Part Description	Quantity
58571-33010	Upper Tibia Pad	1
78118-41010	Rubber Pad	1

B. TOOLS & EQUIPMENT

- Dust mask
- Hair dryer or heat gun
- Hand file
- Orbital sander *
- Protective eyewear
- Protective work gloves
- Reciprocating Saw *
- Scribe
- Standard hand tools
- Techstream
- Torque wrench
- Workbench with vise

* One orbital sander and one reciprocating saw will be provided to each dealership.

C. ACCELERATOR PEDAL TEMPLATE & GAUGE

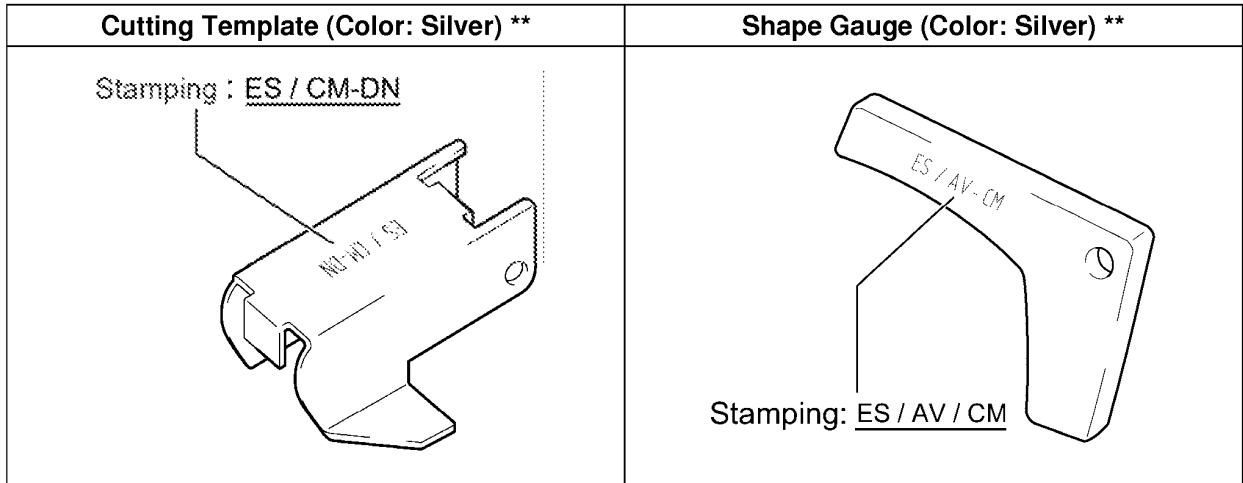

** One cutting template and one shape gauge will be provided to each dealership.

D. MATERIALS

- Bubble wrap
- Double sided tape – (3/4" wide Scotch ® Heavy Duty Mounting Tape 110-Long)
- Industrial tape – (2" wide Gorilla Tape ®)
- Masking tape
- Sandpaper 400 grit
- Shop cloth

IV. BACKGROUND

In early October, Toyota announced it will initiate a Safety Recall Campaign (Special Service Campaign) for potential floor mat interference with the accelerator pedal. The condition involves the potential for an unsecured or incompatible driver's floor mat to interfere with the accelerator pedal and cause it to get stuck in the wide open position.

- The accelerator pedal will be modified to reduce the risk of an unsecured or incompatible floor mat from interfering with the accelerator pedal.
- Foam pads underneath the carpet in the accelerator pedal area will also be removed and/or replaced to modify the shape of the floor.
- Vehicles equipped with the optional genuine Toyota All Weather Floor Mats (AWFM) will be inspected to determine if the AWFM set is of an older design. If it is, the older design AWFM for the driver and the front passenger will be replaced with newly designed ones.
- Finally, the ECM will be reflashed with newly designed software to provide customers an extra measure of confidence. This reflash will allow the system to cut engine power in case of simultaneous application of both the accelerator and brake pedals during certain driving speeds.

V. WORK PROCEDURE

A. COMPONENTS

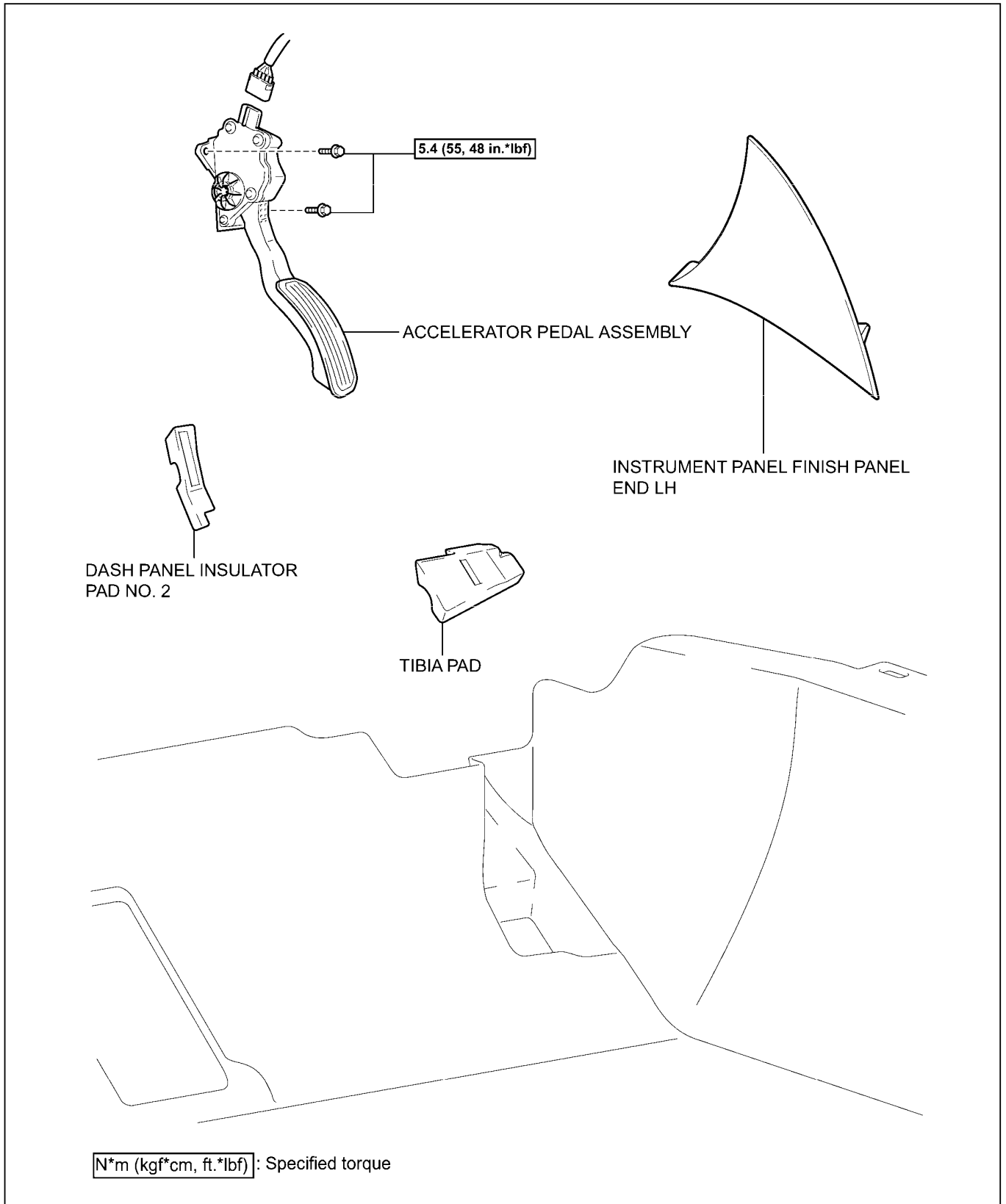

B. REMOVE AND CUT THE ACCELERATOR PEDAL



ACCELERATOR PEDAL HANDLING NOTES:

- DO NOT drop
- DO NOT reuse an accelerator pedal that has been dropped.
- Avoid vibration and shock
- DO NOT place sensor in vise
- Cover and uncover the sensor while in the vehicle to prevent damage and debris from entering

[CLICK HERE TO WATCH THE VIDEO BEFORE BEGINNING THE WORK PROCEDURE.](#)

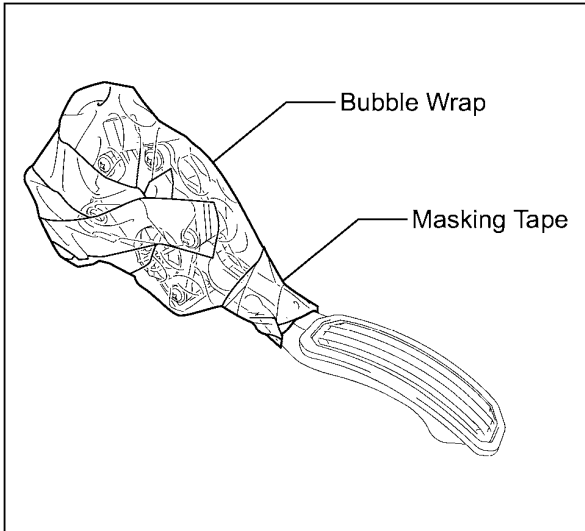

1. REMOVE THE ACCELERATOR PEDAL ASSEMBLY

[Click here to watch the video to supplement this step.](#)

- Disconnect the accelerator pedal connector.
- Remove the 2 bolts.
- While still inside the vehicle, use bubble wrap and masking tape to cover and protect the sensor.

NOTE:

- For additional information on accelerator pedal removal, please refer to TIS.
- Be sure to use bubble wrap to protect the sensor.
- Be sure to seal the bubble wrap with masking tape to prevent damage to the sensor, and cutting debris from entering the pedal's movable lock.
- DO NOT reuse the bubble wrap.

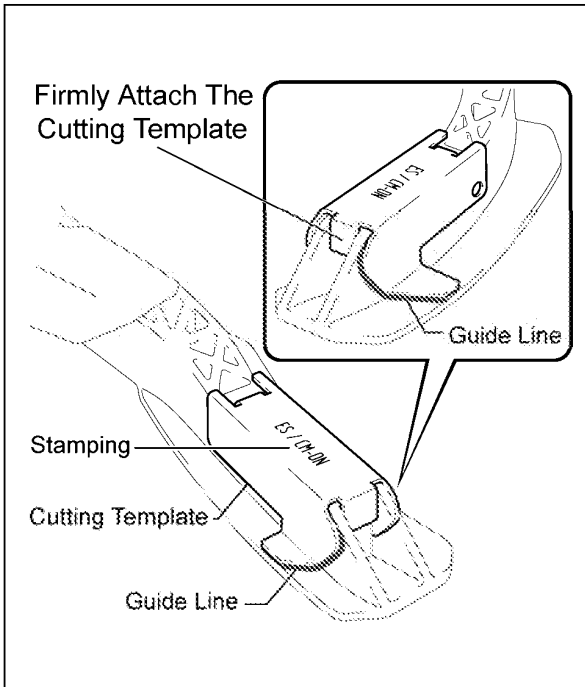

2. MARK THE AREA TO BE CUT

[Click here to watch the video to supplement steps 2 and 3.](#)

- Firmly set the template to the pedal and scribe guide lines to outline the area to be cut.

Cutting Template:

- Color: Silver
- Stamping: ES / CM-DN

NOTE:

- DO NOT mark the area beyond the template.
- Use a flat tip screwdriver if a scribe is not available.
- Make sure to use the correct cutting template by verifying the color and stamping.
- Never cut or sand the pedal while the template is on the pedal.

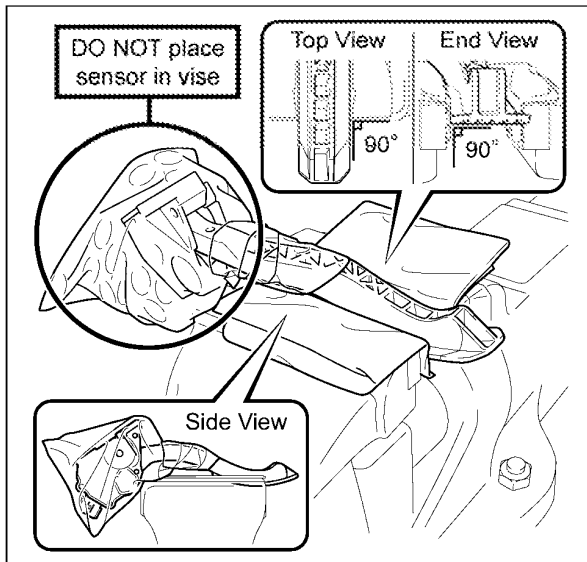

3. SECURE THE ACCELERATOR PEDAL ASSEMBLY

- a) Set the pedal in the vise at a right angle using a shop cloth while avoiding the sensor.

NOTE:

- **DO NOT** place the sensor in the vise to avoid damage.
- **Firmly secure** the pedal to prevent it from moving.
- **DO NOT** over tighten the vise.

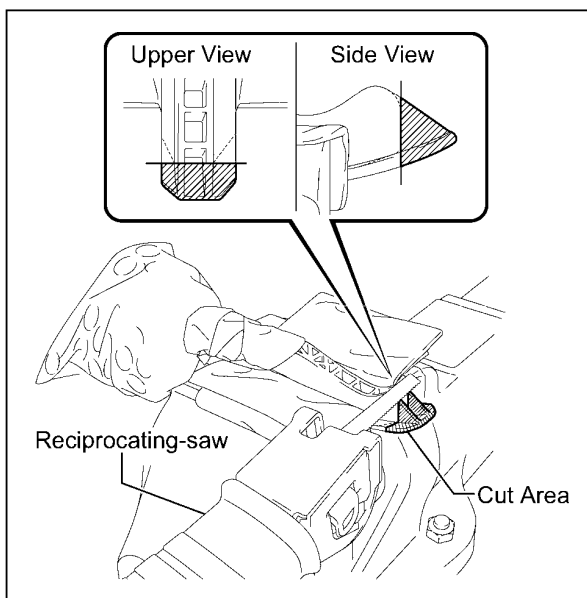

4. CUT THE ACCELERATOR PEDAL

Click [here](#) to watch the video to supplement steps 4 through 7.

- a) Using a reciprocating saw, cut the lower section of the pedal.

NOTE:

- **Always wear protective eyewear, gloves, and dusk mask when cutting.**
- **The cut must be straight and clean.**
- **Apply consistent pressure during cutting.**
- **Do not stop while cutting.**

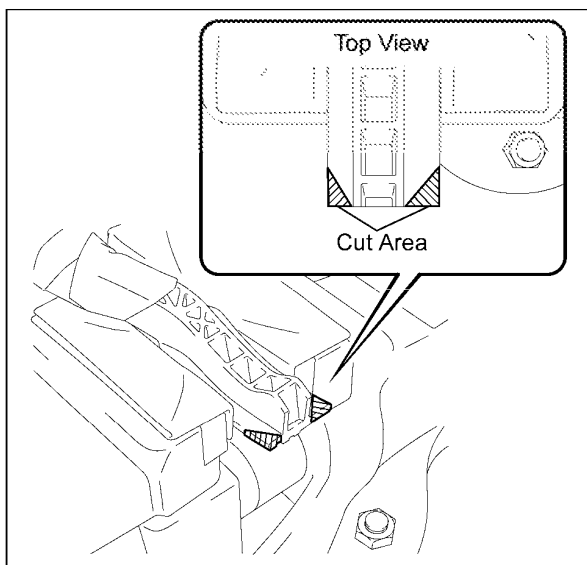

- b) Using a reciprocating saw, cut the corners of the pedal.

NOTE:

- **Always wear protective eyewear, gloves, and dusk mask when cutting.**
- **Each cut must be straight and clean.**
- **Apply consistent pressure during cutting.**
- **Do not stop while cutting.**

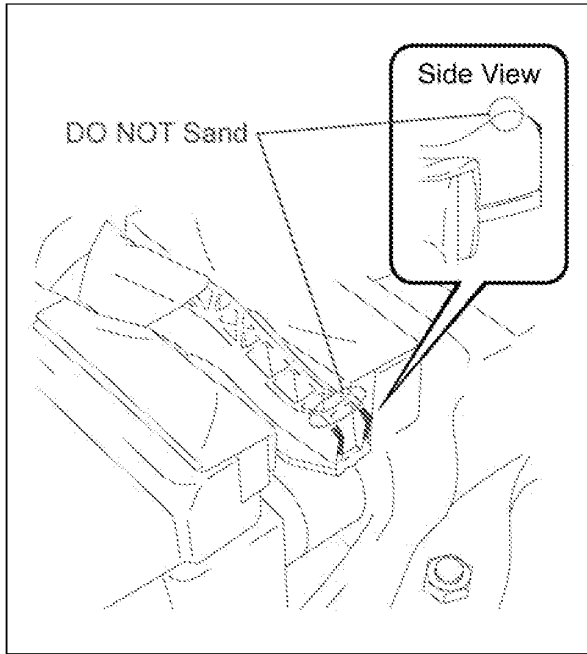

5. SAND THE RADIUS LINE

- Using an orbital sander, sand the radius line which was scribed and remove the sharp edges and burrs.

NOTE:

- Always wear protective eyewear, gloves, and dusk mask when sanding.
- DO NOT sand the back of the pedal arm.

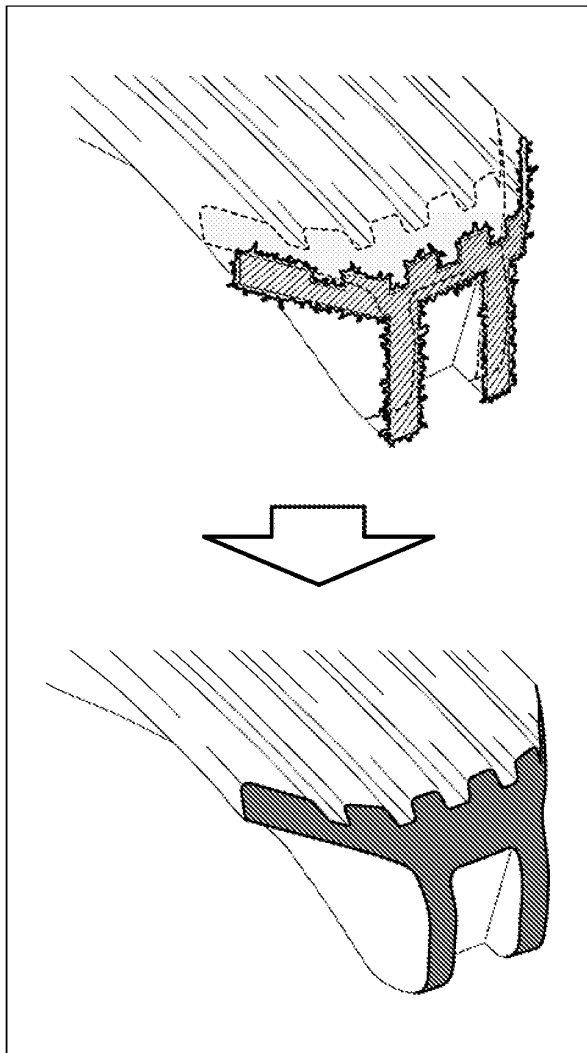

6. REMOVE ALL BURRS FROM THE CUT SURFACE

- Remove the pedal from the vise.
- Turn the pedal over and set it pedal in the vise using a shop cloth while avoiding the sensor.
- Using an orbital sander and file, remove all burrs from the cut surface. The cut edges along the foot pad should be rounded and not square.
- Finish the cut surface and all edges with 400 grit sandpaper.

NOTE:

- Always wear protective eyewear, gloves, and dusk mask when sanding or filing.
- DO NOT place the sensor in the vise to avoid damage.
- Firmly secure the pedal to prevent it from moving.
- DO NOT over tighten the vise.

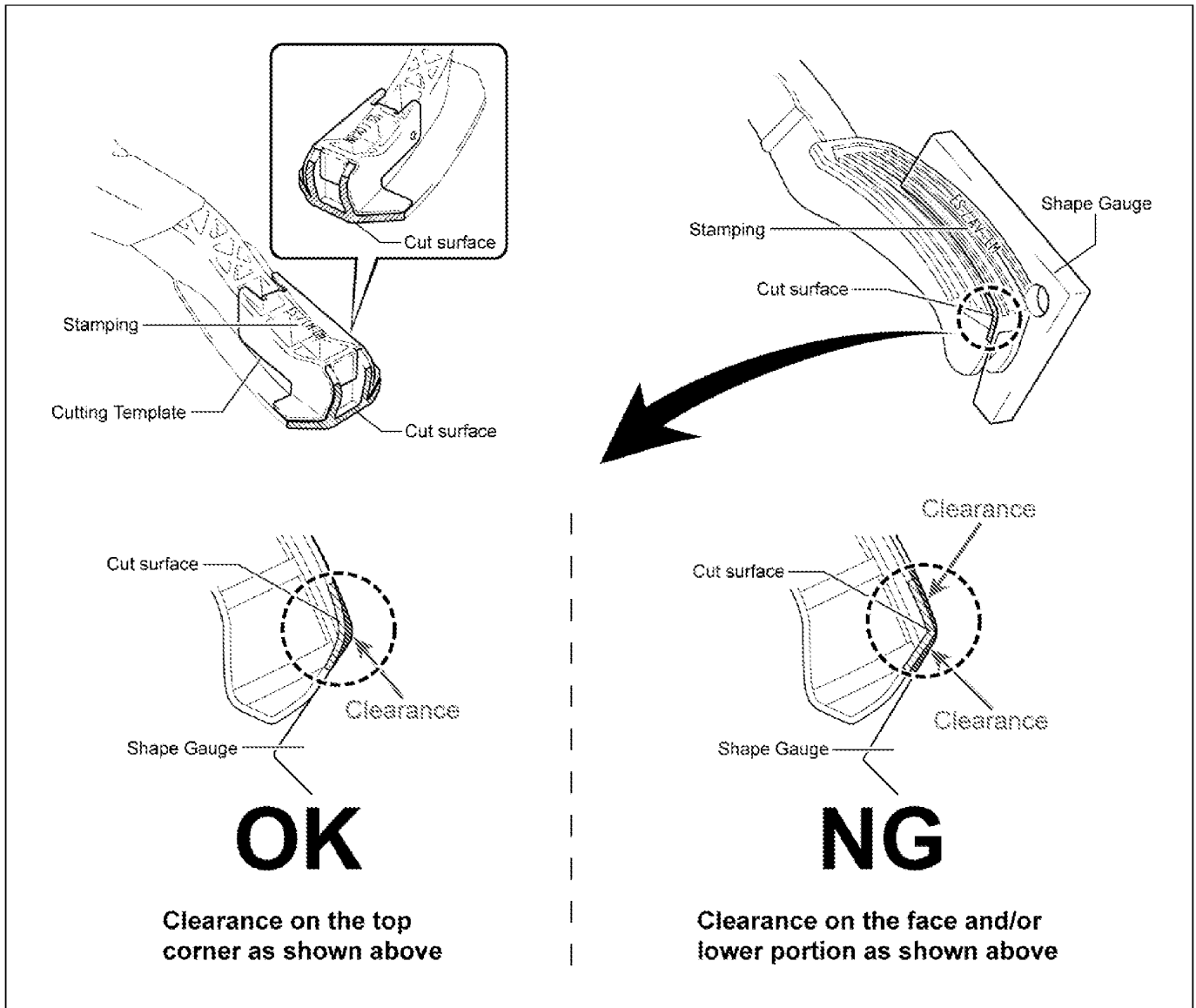

7. CHECK THE SHAPE OF THE PEDAL

- a) Using the correct cutting template and shape gauge, check the shape of the pedal.

Cutting Template:

- Color: Silver,
- Stamping: ES / CM-DN

Shape Gauge:

- Color: Silver
- Stamping: ES / AV / CM

- b) If the shape does NOT match the template and/or gauge, continue filing.

- c) If the shape matches the template and gauge, touch the cut surface with your hand to verify it is smooth and free of burrs.

NOTE:

- **Always wear protective eyewear, gloves, and dusk mask when sanding or filing.**
- * A tolerance of -1.0 mm is permissible between the final cut surface and the template.

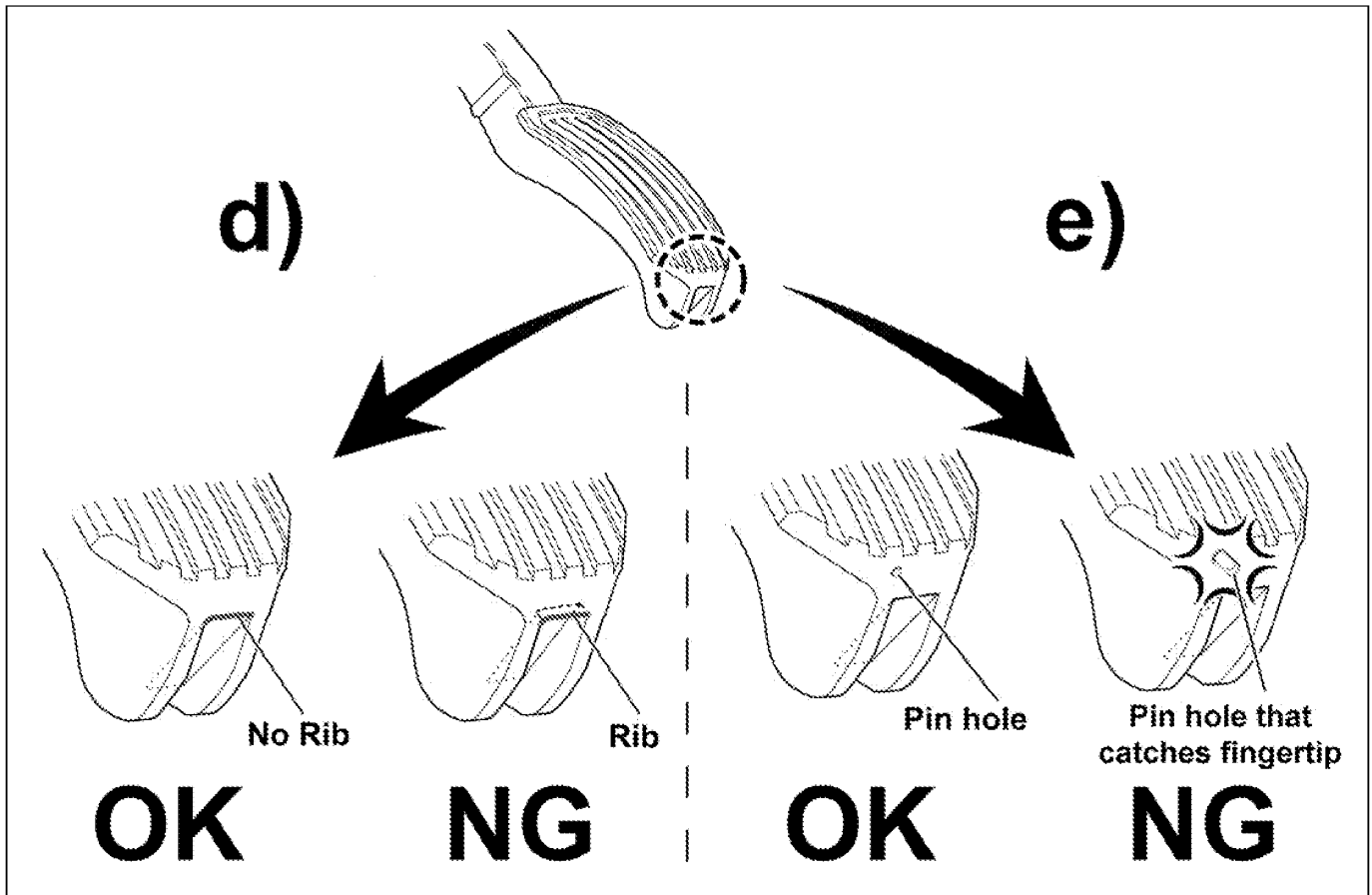

d) Check for a rib as shown. If there is a rib, file it until it is gone.

e) Check for a pin hole on the finished surface. If there is a pin hole, touch it with your fingertip. If the edges of hole catch your fingertip, replace and modify a new pedal.

NOTE:

Regarding the pin hole, the key point of judgment is a “smooth pedal surface”, not necessarily size.

C. FLOOR CARPET MODIFICATION

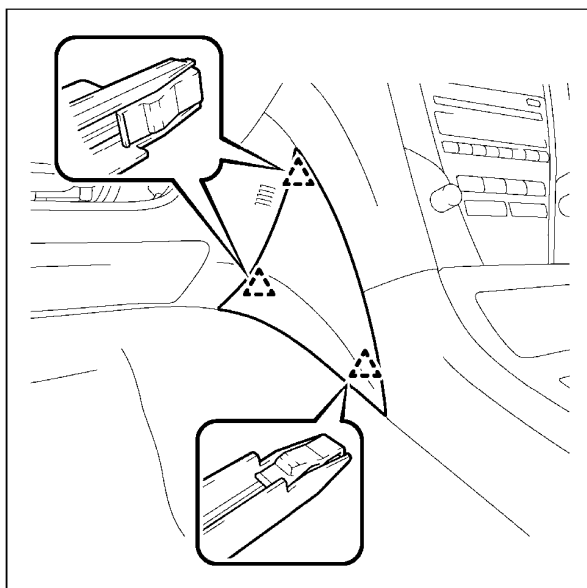

1. REMOVE THE INSTRUMENT PANEL FINISH PANEL END LH

Click [here](#) to watch the video to supplement steps 1 through 7.

- a) Disengage the 3 clips and remove the instrument panel finish panel end LH.

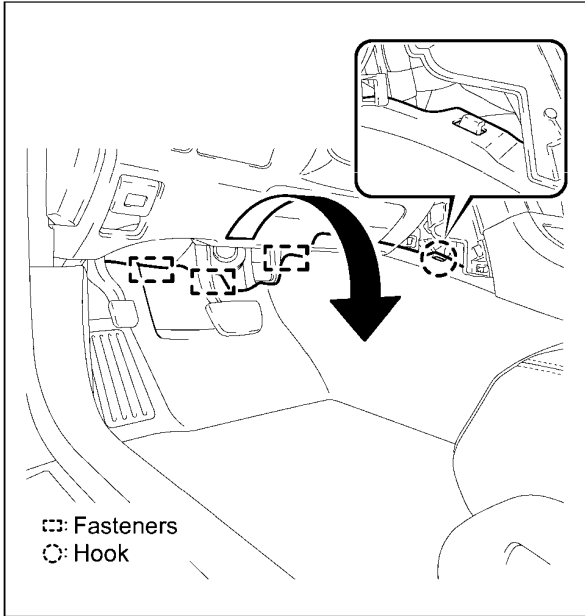

2. PULL BACK THE FLOOR CARPET

- a) Disengage the 3 fasteners.
- b) Disengage the floor carpet from the hook and pull it back as illustrated.

NOTE:

Make sure not to remove the tibia pads when pulling back the carpet.

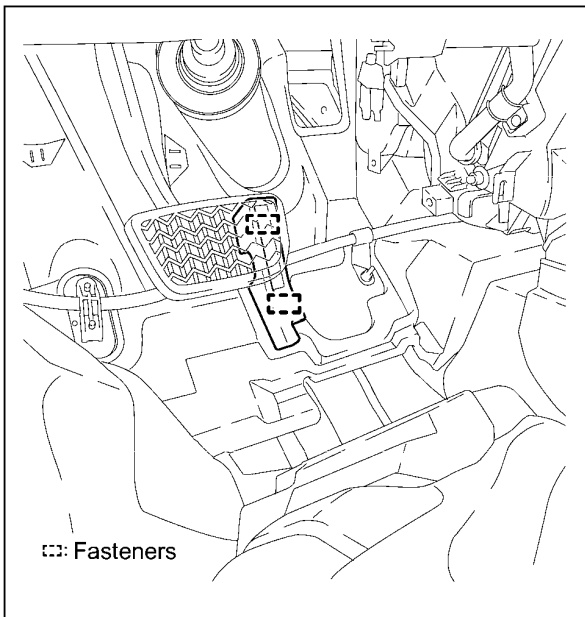

3. REMOVE THE DASH PANEL INSULATOR PAD NO. 2

- a) Disengage the 2 fasteners to remove and discard the dash panel insulator pad No. 2.

NOTE:

The dash panel insulator No. 2 will not be reused, make sure to discard it after removal.

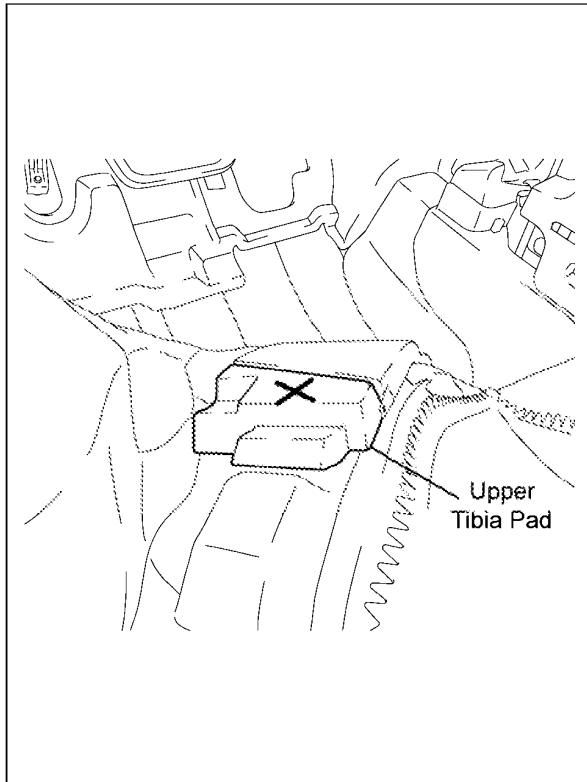

4. REMOVE THE UPPER TIBIA PAD

- a) Place an "X" mark on the upper tibia pad before removing. This will prevent them from being mixed up with the new pads.
- b) Using a ball point pen, outline the location of the upper and lower tibia pads on the carpet for positioning reference.

- c) Using a hair dryer or a low temperature heat gun, warm up the backside of the upper tibia pad until the adhesive is loose. This will make it easier to remove the upper tibia pad from the carpet. *Pay close attention when using the hair dryer or low temperature heat gun to prevent damage to the carpet.*
- d) Remove the upper tibia pad. **CAUTION: DO NOT** forcefully pull the pads. Doing so may damage the carpet. If necessary, re-heat the carpet to make the adhesive more pliable.

NOTE:

- **DO NOT** damage the lower tibia pad.
- If both tibia pads detach from the carpet before their location is outlined, please refer to APPENDIX "B" for "RELOCATING DETACHED TIBIA PADS".

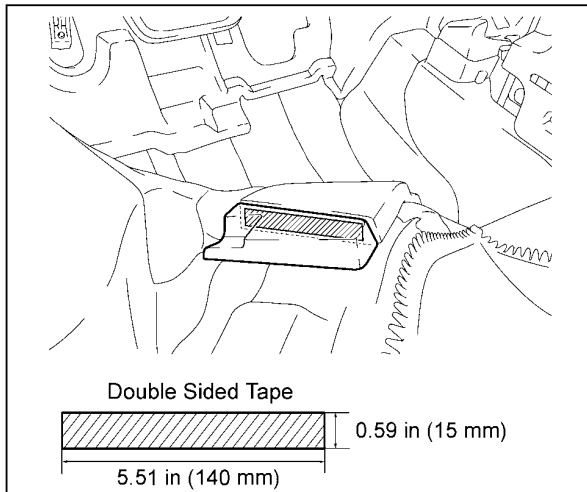

5. INSTALL THE NEW UPPER TIBIA PAD

- a) Using a 0.59 in. (15 mm) x 5.51 in. (140 mm) piece of double sided tape, install the **NEW** upper tibia pad.

NOTE:

- **Make sure to securely install the NEW upper tibia pad in the proper location to avoid fitment issue when reinstalling the carpet.**
- **The upper tibia pad cut out faces the floor panel when the carpet is installed.**

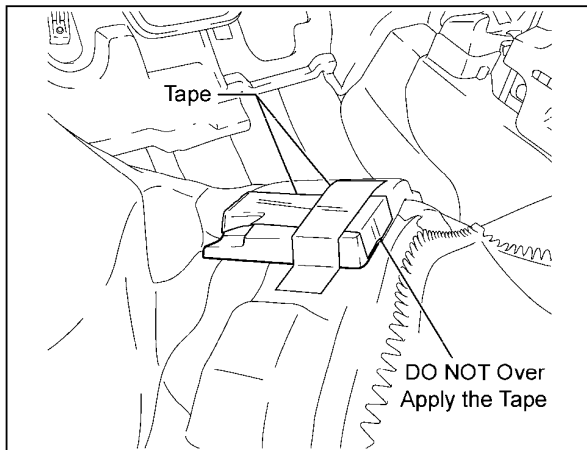

- b) Secure the **NEW** upper tibia pad to the lower tibia pad, by applying the industrial tape to the locations shown.

NOTE:

- **DO NOT** over apply the tape past the joint portions of the two tibia pads.
- **Press the tape firmly onto tibia pads.**
- **Make sure there are no wrinkles on the tape.**
- If both tibia pads detached from the carpet before their location is outlined, please refer to APPENDIX "B" for "RELOCATING DETACHED TIBIA PADS".

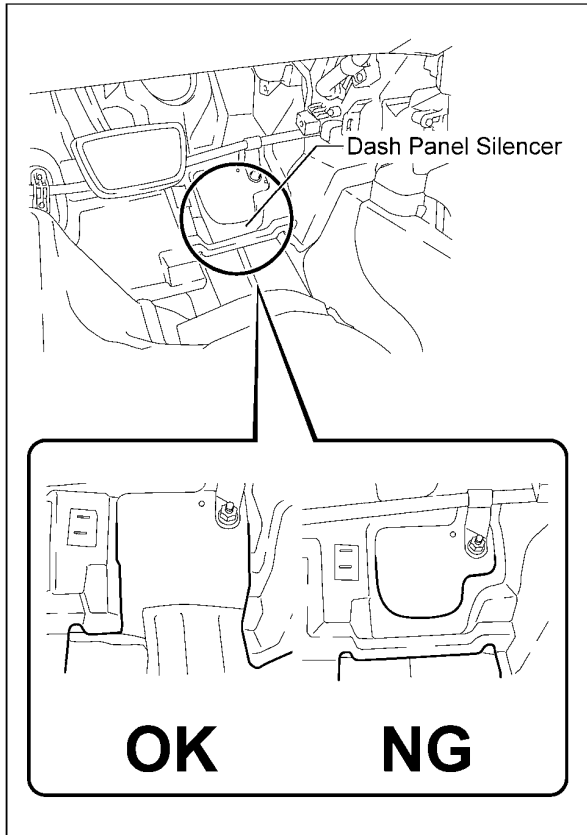

6. INSPECT THE LOWER PORTION OF THE FABRIC FLOOR SILENCING MATERIAL

- a) Inspect the lower portion of the fabric floor silencing material.
- If OK, proceed to step 7 "RUBBER PAD APPLICATION" below.
 - If NG, please refer to APPENDIX "C" for "CUT THE FLOOR SILENCING MATERIAL".

NOTE:

The fabric floor silencing material is a soft, gray, paper-like material beneath the carpet.

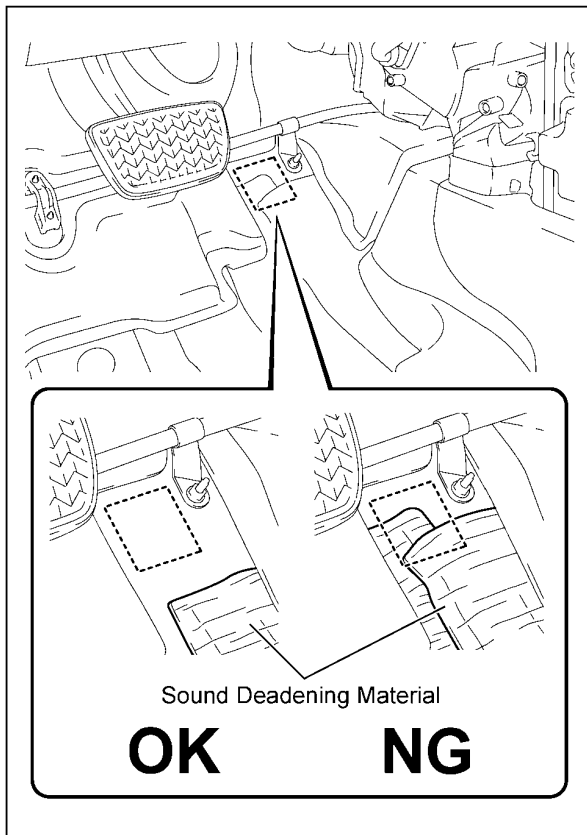

7. RUBBER PAD APPLICATION

- a) Inspect the rubber pad application area for sound deadening material.
- If OK (no sound deadening material in pad application area), proceed to step "b" on the next page.
 - If NG (sound deadening material found in application area), please refer to APPENDIX "D" for "REMOVE THE SOUND DEADENING MATERIAL".

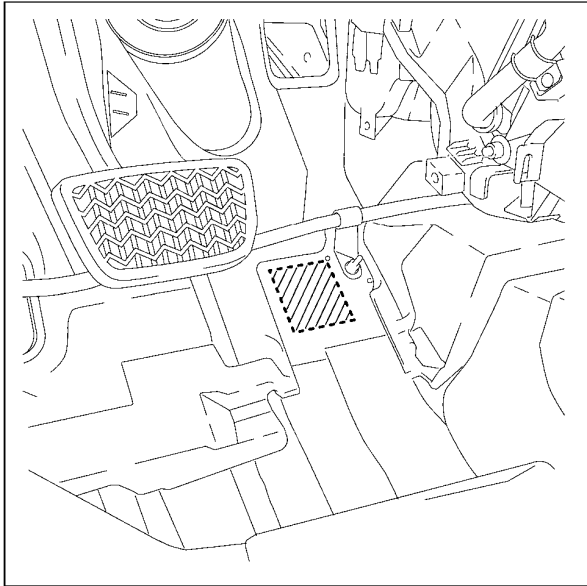

b) Clean and degrease the rubber pad application area.

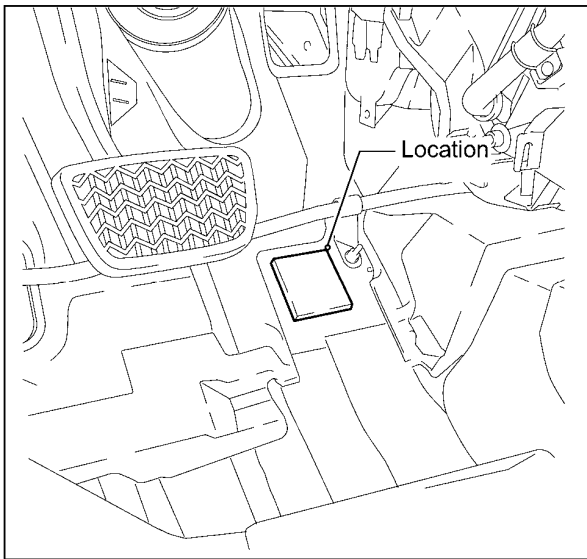

- c) Peel the double sided tape cover off the **NEW** rubber pad.
- d) Apply the rubber pad to the floor pan. The upper right corner of the rubber pad needs to be positioned next to the locating protrusion.

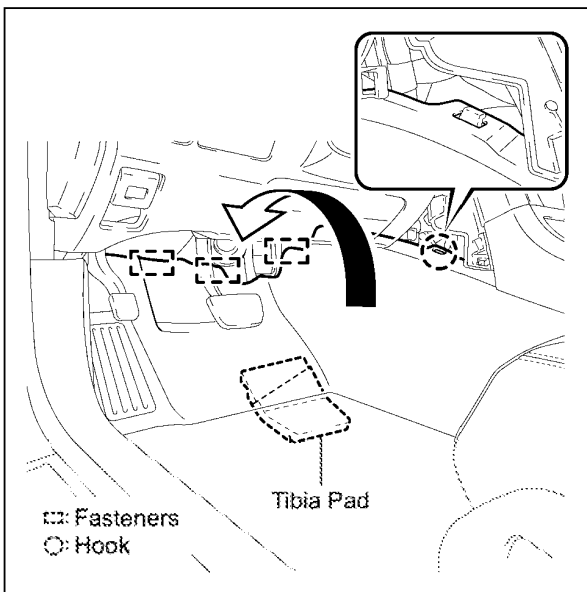

- e) Place the floor carpet back into position and engage the hook as shown in the illustration.
- f) Engage the 3 fasteners.

NOTE:
Be careful not to detach the tibia pads when placing the carpet back into position.

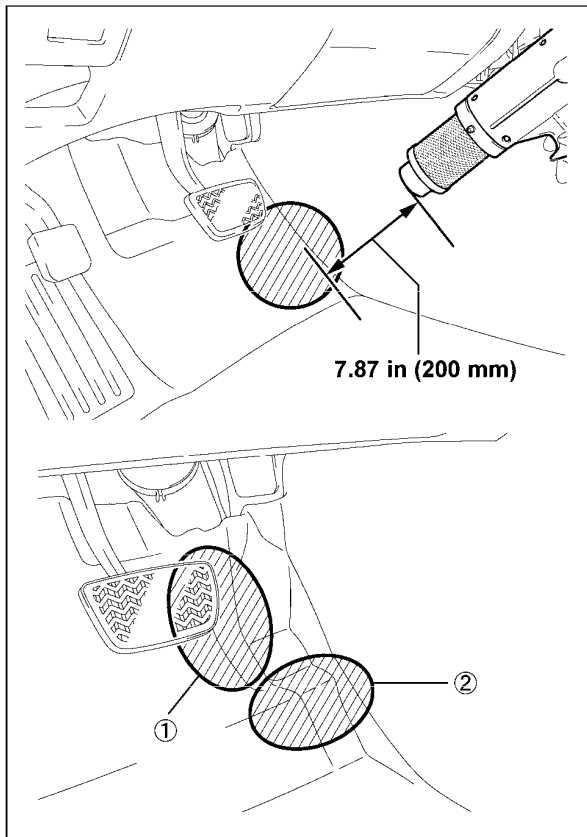

- g) Heat the floor carpet area No. 1 as shown for 2 minutes, and smooth it out by pushing it with your hand.
- h) Heat the floor carpet area No. 2 as shown for 2 minutes, and smooth it out by pushing it with your hand. Heat same area again for another minute, and smooth the carpet firmly.

NOTE:

- Always wear protective gloves when heating the floor carpet.
- Keep the hair dryer/ low temperature heat gun more than 8 inches (20 cm) away from the floor carpet, and stop after 1 or 2 minute intervals. Continuous heating of the floor carpet may cause damage.
- DO NOT leave hair drier or low temperature heat gun inside the vehicle when it is hot, to prevent unintended heat damage to interior parts.

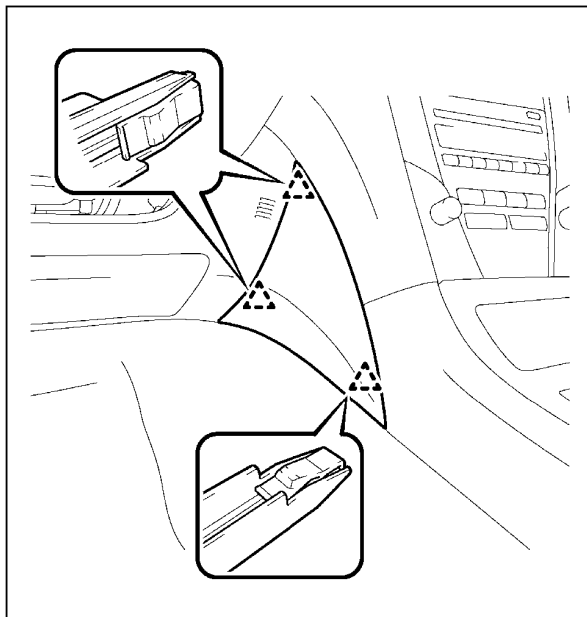

8. REINSTALL THE INSTRUMENT PANEL FINISH PANEL END LH

- a) Reinstall the instrument panel finish panel end LH by engaging the 3 clips.

D. REINSTALL THE ACCELERATOR PEDAL ASSEMBLY

1. REINSTALL THE ACCELERATOR PEDAL ASSEMBLY

[Click here to watch the video to supplement this step.](#)

- Remove and discard the masking tape and bubble wrap from the accelerator pedal assembly, while it is inside the vehicle.
- Reinstall the pedal with the 2 bolts and torque to specification.

Torque Specification:
5.4 Nm (55 kgf cm, 48 in. lbf)

- Reconnect the accelerator pedal connector.

NOTE

- DO NOT reuse the bubble wrap.
- For additional information on accelerator pedal installation, please refer to TIS.

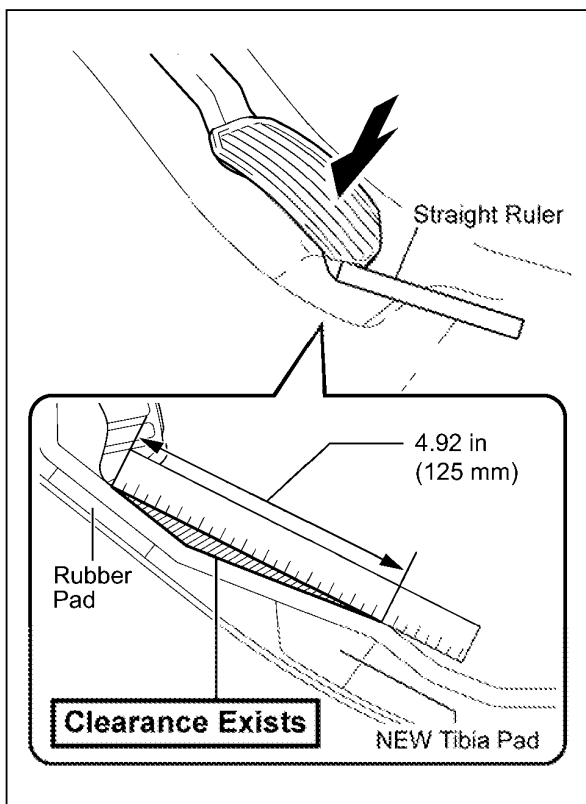

2. INSPECT THE FLOOR CARPET

- With the accelerator pedal fully depressed, confirm clearance exists between the floor carpet and the straight ruler as shown.
- If no clearance exists, reshape the carpet again.
- Confirm the claw and all fasteners of the floor carpet are securely attached.

3. INSPECT ACCELERATOR PEDAL OPERATION

- a) Confirm the correct floor mat for this model is secured with the retaining hooks (clips).
- If the grommets in the floor for the vehicle are in poor condition, refer to the appropriate TSB and repair the grommets.

NOTE:

- If a Recalled All Weather Floor Mat (AWFM) has been identified, remove the AWFM from the vehicle and CUT THE RECALLED AWFM SO THAT IT CANNOT BE REUSED.
- You may remove the semi-permanent installation plastic straps for the carpeted floor mat once the repair is completed.

Locate the ten digit floor mat part number on the bottom of the back side of the mat as illustrated below. PLEASE NOTE, the floor mat part numbers are 12 digits but only the first ten are shown.

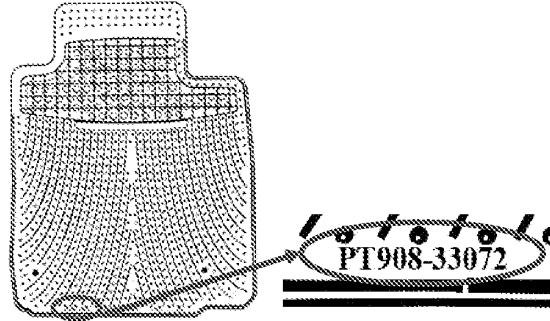

For Carpeted Floor Mats:

Utilizing the ten digit part number and the chart below, confirm the vehicle has the correct carpeted floor mat.

Part Number	Model	Type	'07	'08	'09	'10	Color
PT548-33070-02	ES350	Carpet	x	x	x	x	Black
PT548-33070-11	ES350	Carpet	x	x	x	x	Lt Gray
PT548-33070-10	ES350	Carpet	x	x	x	x	Cashmere
PT548-33080-02	ES350 Special Edition	Carpet			x	x	Black
PT548-33080-10	ES350 Special Edition	Carpet			x	x	Cashmere
PT548-33080-11	ES350 Special Edition	Carpet			x	x	Lt Gray
PT548-33090-01	ES350	Carpet			x	x	Brown
PT548-33090-12	ES350	Carpet			x	x	Charcoal
PT206-33070-10	ES350	Carpet			x	x	Cashmere
PT206-33070-11	ES350	Carpet			x	x	Lt Gray
PT206-33090-05	ES350	Carpet			x	x	Brown
PT206-33090-15	ES350	Carpet			x	x	Charcoal
PT206-33090-25	ES350	Carpet			x	x	Black

For All Weather Floor Mats (AWFM):

Utilizing the ten digit part number and the chart below, confirm the vehicle has the correct AWFM.

Part Number	Model	Type	'07	'08	'09	'10	Color
PT908-3310W-02	ES350	All Weather	x	x	x	x	Black
PT908-3310W-11	ES350	All Weather	x	x	x	x	Gray
PT908-3310W-14	ES350	All Weather	x	x	x	x	Brown

NOTE:

The part numbers listed above are for the 2 piece (driver & front passenger) campaign set ONLY.

DO NOT use the recalled AWFM listed below. These AWFM must be removed from the vehicle and recovered by the dealer.

Part Number	Model	Type	'07	'08	'09	'10	Color
PT908-33070-02	ES350 – Do not use	All Weather	x				Black
PT908-33070-11	ES350 – Do not use	All Weather	x				Gray
PT908-33070-14	ES350 – Do not use	All Weather	x				Brown
PT908-33071-02	ES350 – Do not use	All Weather	x	x			Black
PT908-33071-11	ES350 – Do not use	All Weather	x	x			Gray
PT908-33071-14	ES350 – Do not use	All Weather	x	x			Brown
PT908-3307F-02	ES350 – Do not use	All Weather	x	x	x	x	Black
PT908-3307F-11	ES350 – Do not use	All Weather	x	x	x	x	Gray
PT908-3307F-14	ES350 – Do not use	All Weather	x	x	x	x	Brown
PT908-33072-02	ES350 – Do not use	All Weather	x	x	x	x	Black
PT908-33072-11	ES350 – Do not use	All Weather	x	x	x	x	Gray
PT908-33072-14	ES350 – Do not use	All Weather	x	x	x	x	Brown

All recalled AWFM will be placed on Warranty Parts Recovery, and dealers will be required to return them to TMS. AWFM that are not returned will result in the claim being debited.

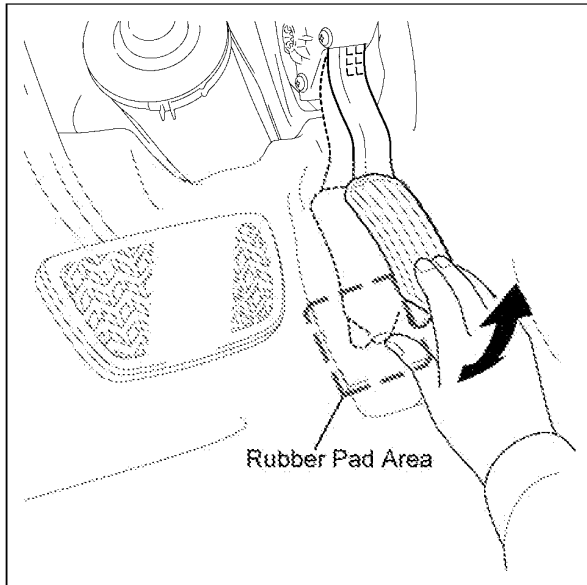

- b) Confirm the pedal does not get caught on the floor or floor mat during operation.
- c) Confirm the pedal operates properly.
- d) Confirm the bottom of pedal contacts on the area of rubber pad when the accelerator pedal fully depressed.

4. INSPECT THE ACCELERATOR PEDAL ASSEMBLY OPERATION

- a) Connect Techstream to the DLC3.
- b) Enter the following menus: Chassis / Engine and ECT / Data List.
- c) Check the values by referring to the table below.

Tester Display	Measurement: Range (Display)	Normal Condition	Diagnostic Note
Accelerator Opening Angle	Accelerator Opening Angle	Accelerator Pedal Released: 0%	-
	Min: 0%, Max: 100%	Accelerator Pedal Fully Depressed: 100%	

Model Year	Current CID	New CID
2007	33375100	33375200
	33375000	
2008 - 2009	333A9100	333A9200
	333A9000	
2010	333C7000	333C7100

5. REFLASH THE ECU

- a) Reflash the Engine ECU with the **NEW** Override System software following TSIB SS002-07.
- b) For Calibration ID, please refer to the table on the left.

6. CHECK FOR DTC CODES

- a) Connect the Techstream to the DLC3.
- b) Check for DTC codes.

NOTE:

If DTC(s) are displayed, verify the code(s) and record the freeze frame data, then perform repairs as necessary.

7. TEST DRIVE THE VEHICLE AND INSPECT FOR ANY PROBLEMS

VI. APPENDIX

A. RECALLED PARTS DISPOSAL

As required by Federal Regulations, please make sure all recalled parts (original parts) removed from the vehicle are disposed of in a manner in which they will not be reused, **unless requested for parts recovery return.**

B. RELOCATING DETACHED TIBIA PADS

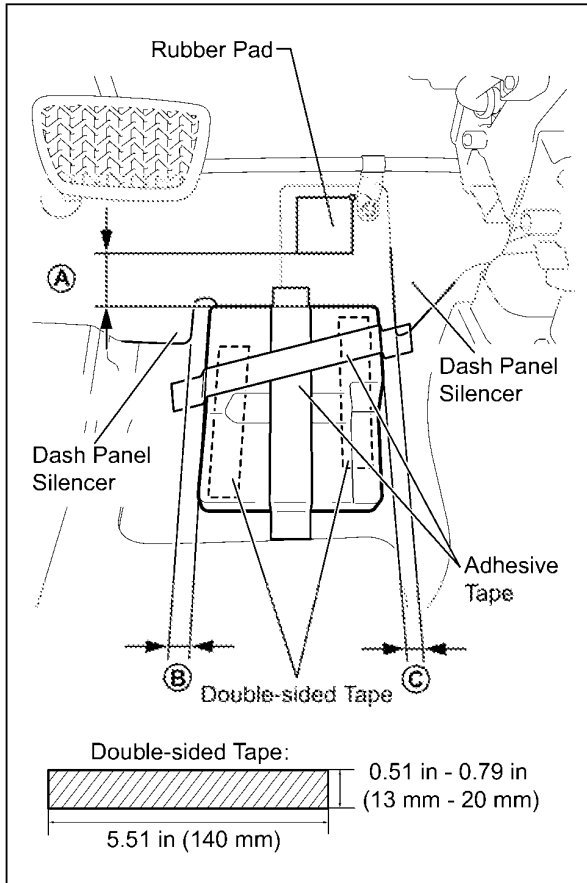

1. In the event the lower tibia pad has detached from the carpet following the steps below.
 - a) Apply double sided tape to the bottom (floor pan side) of the tibia pads as illustrated.
 - b) Position the tibia pads on the floor pan as indicated using the rubber pad and chart below as a guide.
 - c) Apply a piece of industrial adhesive tape from the top to the bottom of the tibia pads.
 - d) Apply a second piece of industrial adhesive tape from the left to the right side of the tibia pads.

NOTE:

- Use the rubber pad's lower edge as a guide to position the top section of the tibia pads.
- Use floor side member as a guide to position the right section of the tibia pads.
- Angle the industrial adhesive tape running left to right to ensure that both tibia pads are covered.
- Both pieces of industrial adhesive tape should have a good contact surface to the floor pan.

Part	Length	
A	2.14 in	54.4 mm
B	0.54 in	13.8 mm
C	0.81 in	20.5 mm

C. CUT THE FABRIC FLOOR SILENCING MATERIAL

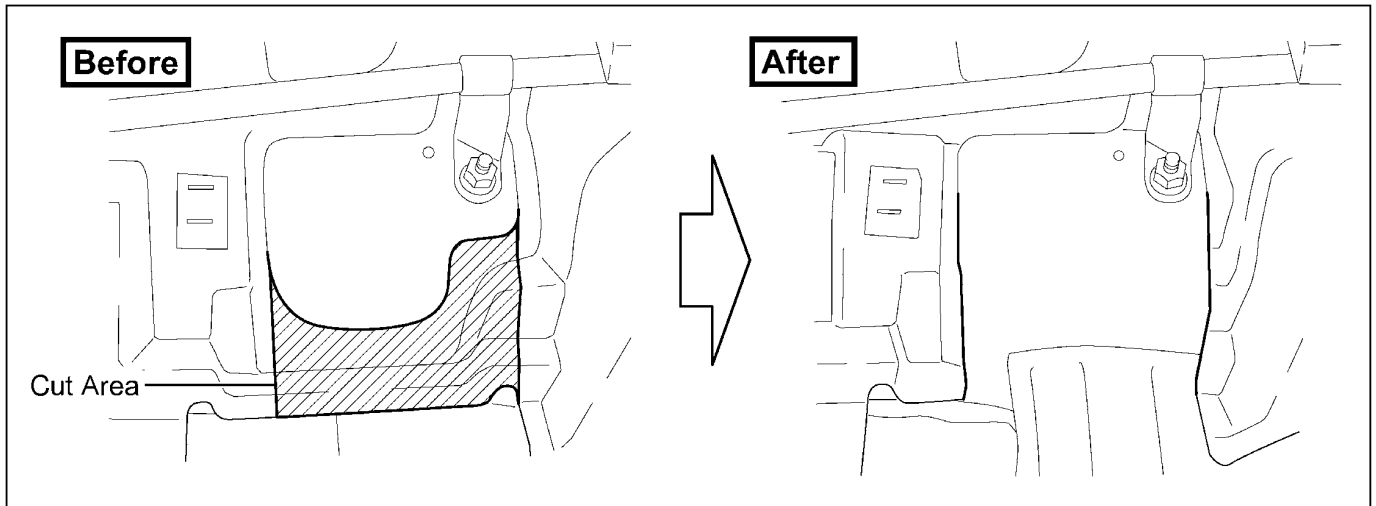

D. REMOVE THE SOUND DEADENING MATERIAL

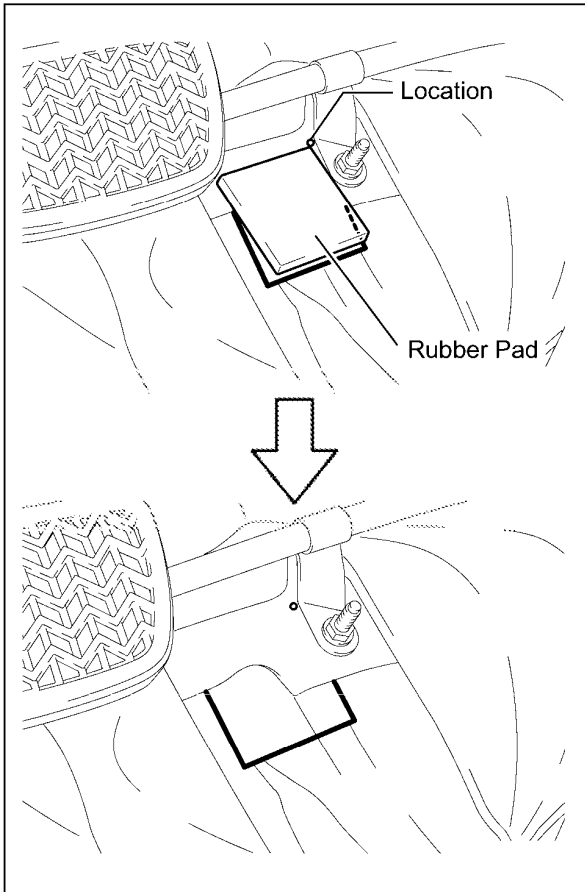

1. Temporarily place the rubber pad on the floor panel as shown, and outline the pad on the sound deadening material with a ball point pen.

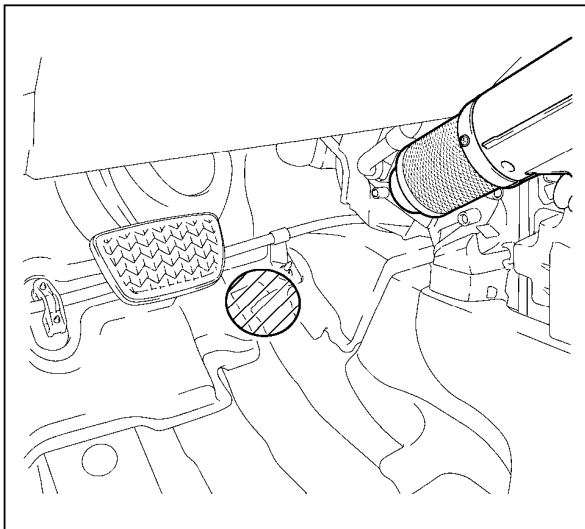

2. Using a hair dryer or low temperature heat gun, warm up the sound deadening material until it becomes soft.

NOTE:

- **Make sure not to damage the fabric floor silencing material.**
- **Pay close attention when using the hair dryer or low temperature heat gun to prevent damage to the carpet.**

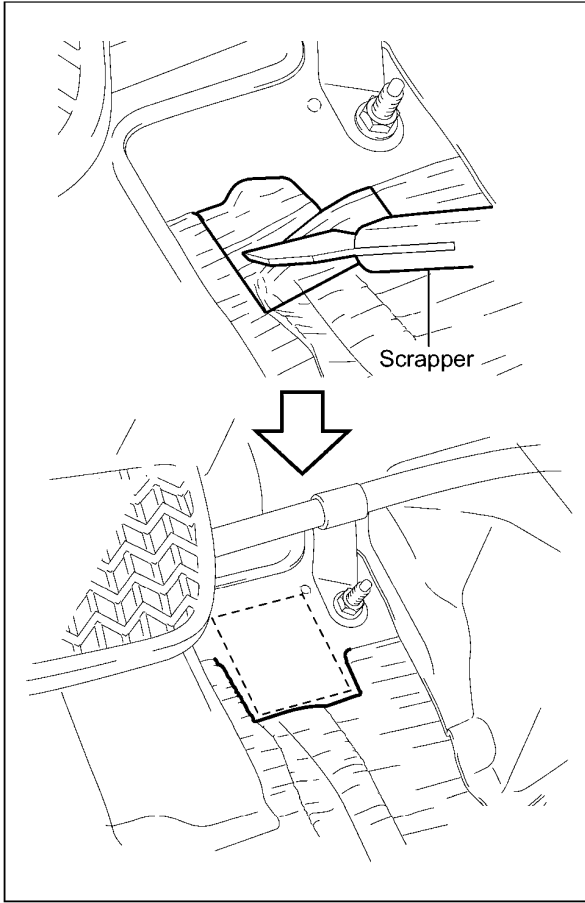

3. Using a scraper, remove the sound deadening material from the rubber pad application area.
4. Remove any loose sound deadening material from the rubber pad application area.

NOTE:

- **Wear protective gloves during the scraping process.**
- **Warm up the sound deadening material again, if it becomes hard during removal.**
- **Remove the sound deadening material until the rubber pad application surface is smooth.**
- **Make sure not to damage the paint film on the floor panel when scraping.**
- **Apply touch up paint if the paint film was damaged.**